

CHANCE® Type SS5 Helical Piles and Anchors

57 kip Ultimate – 28.5 kip Allowable Capacity

Installation Torque Rating – 5,700 ft-lb

Multi-Purpose 1-1/2 inch Solid Round-Cornered-Square Steel Shaft with integrally formed square upset sockets

Description:

Hubbell Power Systems, Inc., CHANCE Type SS5 Helical Piles and Anchors have 57 kip ultimate capacity and 28.5 kip working or allowable capacity in compression or tension. This capacity is based on well documented correlations with installation torque, which is recognized as one method to determine capacity per IBC Section 1810.3.3.1.9. Lead sections and extensions couple together to extend the helix bearing plates to the required load bearing stratum. Solid square shaft helical piles and anchors provide greater penetration into bearing soils and increased axial capacity in firm soils compared to pipe shaft helical piles with similar torque strength. Strength calculations are based on a design corrosion level of 50 years for most soil conditions. CHANCE Type SS Helical Piles and Anchors have a longer service life than do pipe shaft piles because of their reduced surface area. CHANCE Type SS Helical Piles and Anchors feature sharpened leading edge helix plates that are circular in plan to provide uniform load bearing in most soil conditions. Helix plates can be equipped with "sea-shell" cuts on the leading edge to enhance penetration through dense soils with occasional cobbles and debris. Custom lengths and helix configurations are available upon request. See below for additional information and other sections of this Technical Manual for specifications and design details.

DRAWINGS AND RATINGS

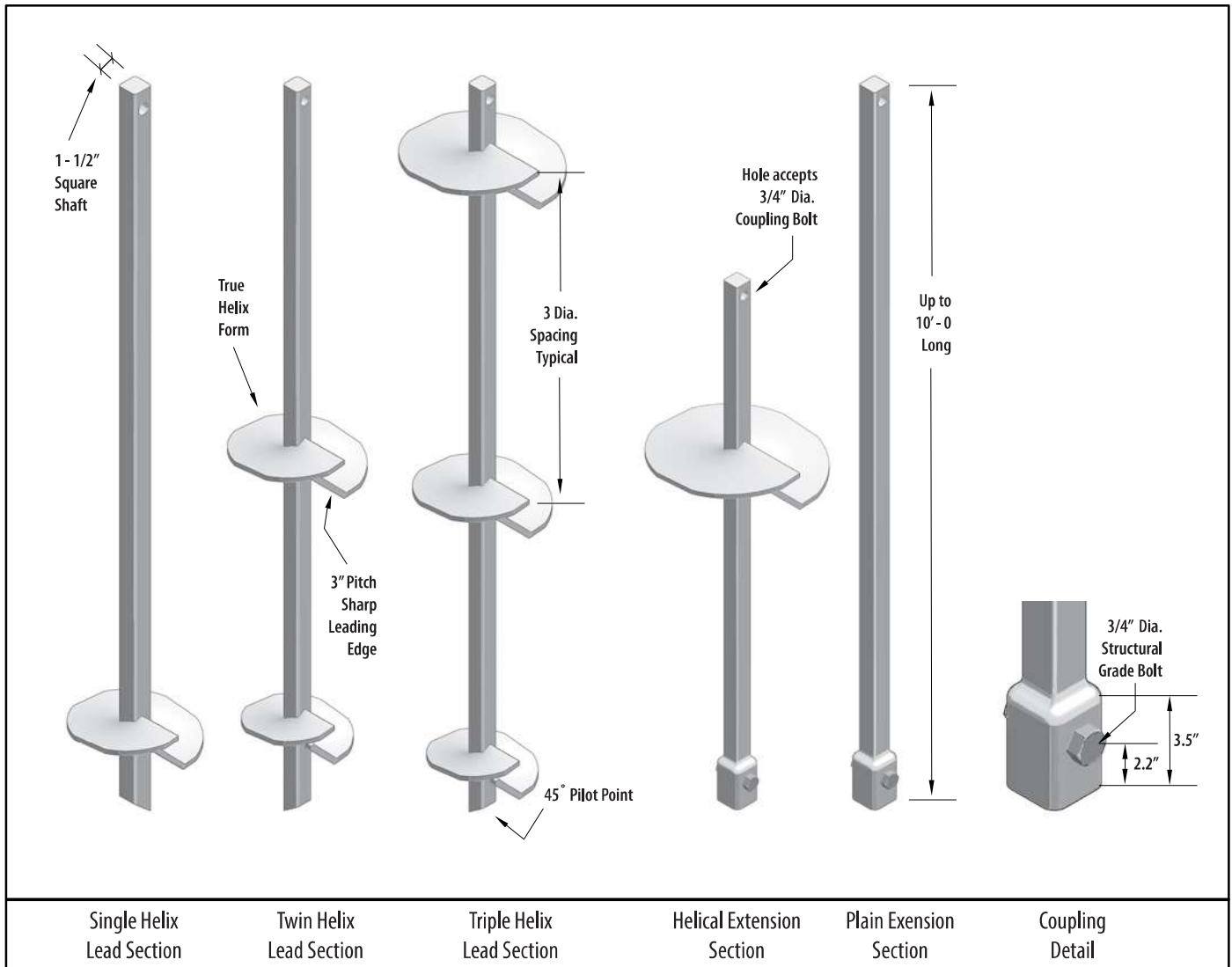

All Hubbell Power Systems, Inc. CHANCE Helical Products are MADE IN THE U.S.A.

SS5 Helical Pile and Anchor Specifications & Available Configurations

Shaft – Round-Cornered-Square (RCS) 1-1/2 inch solid steel shaft produced exclusively for CHANCE products.

Coupling - forged as a deep socket from the steel shaft material as an integral part of the extension, connected with structural bolts.

Helix - 3/8 inch Thick: ASTM A572, or A1018, or A656 with minimum yield strength of 50 ksi.

3 inch Helix Pitch – a standard established by Hubbell Power Systems, Inc. for Helical Piles and Anchors.

Available Helix Diameters: 6, 8, 10, 12, 14, or 16 inches.

All helix plates are spaced 3 times the diameter of the preceding (lower) helix unless otherwise specified.

The standard helix plate has straight sharpened leading edges or can be ordered with a “sea shell” cut. The “sea shell” cut is best suited when it is necessary to penetrate soils with fill debris, cobbles, or fractured rock.

Configurations:

- Single, double, triple, and quad helix Lead Sections, 3, 5, 7, and 10 feet long
- Plain Extensions, 3, 5, 7, and 10 feet long
- Extensions with Helix Plates, 3 and 5 feet long, single helix

Helical products are Hot Dip Galvanized per ASTM A153 Class B-1.

NOTE: Helical piles shall be installed to appropriate depth in suitable bearing stratum as determined by the geotechnical engineer or local jurisdictional authority. Torque correlated capacities are based on installing the pile to its torque rating, using consistent rate of advance and RPM. A minimum factor of safety of 2 is recommended for determining allowable capacity from correlations. Deflections of 0.25 to 0.50 inches are typical at allowable capacity.

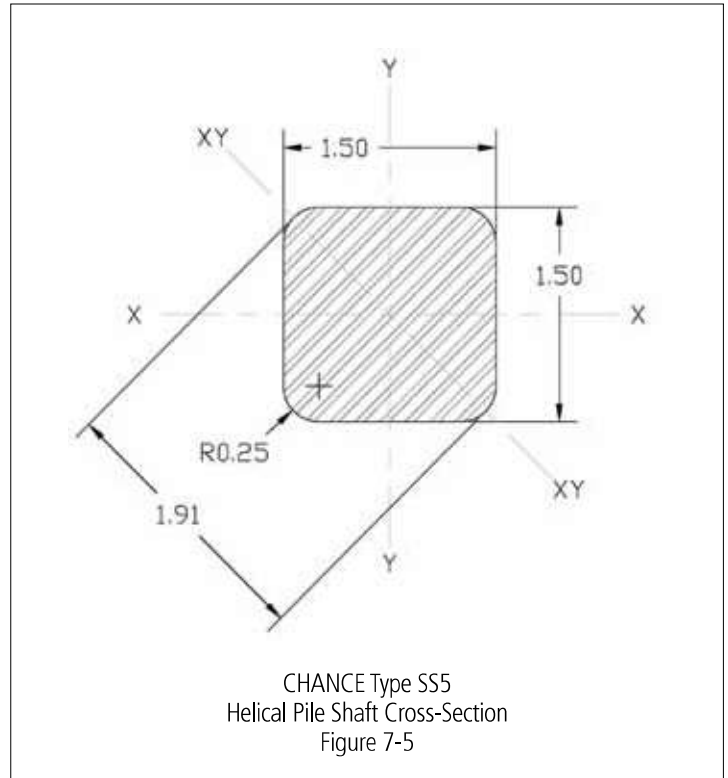

Nominal, LRFD Design and ASD Allowable Strengths of SS5 Helix Plates for Shaft Axial Tension and Compression¹

Helix Diameter in (mm)	Thickness in (mm)	Nominal Strength kip (kN)	LRFD Design Strength kip (kN)	ASD Allowable Strength kip (kN)
6 (150)	0.375 (9.5)	57.3 (254.9)	51.6 (229.5)	28.7 (127.7)
8 (200)	0.375 (9.5)	57.3 (254.9)	51.6 (229.5)	28.7 (127.7)
10 (250)	0.375 (9.5)	47.7 (212.2)	42.9 (190.8)	23.8 (105.6)
12 (300)	0.375 (9.5)	44.2 (196.6)	39.8 (177.0)	22.1 (98.3)
14 (350)	0.375 (9.5)	54.1 (240.7)	48.7 (216.6)	27.1 (120.6)

For SI: 1 kip = 4.448 kN.

¹Capacities based on a design corrosion level of 50-years.

Nominal and LRFD Design Compression Strengths of CHANCE® Type SS5 Helical Pile Lead & Extension Sections^{1,2}

Section Type & Helix Count	Nominal & LRFD Design Compression Strengths kip (kN)							
	Firm Soil				Soft Soil			
	Fixed		Pinned		Fixed		Pinned	
	Nominal	Design	Nominal	Design	Nominal	Design	Nominal	Design
Lead, Single Helix	See Helix Strength Table		Single 6 & 8 in	Single 6 & 8 in	26.6 (118.3)	24.0 (106.8)	13.6 (60.5)	12.2 (54.3)
			For Other Helix Diameters, See Helix Strength Table					
Lead, Multi-Helix	89.8 (399.5)	80.8 (359.4)	54.4 (242.0)	48.9 (219.5)	26.6 (118.3)	24.0 (106.8)	13.6 (60.5)	12.2 (54.3)
Extension	89.8 (399.5)	80.8 (359.4)	54.4 (242.0)	48.9 (219.5)	26.6 (118.3)	24.0 (106.8)	13.6 (60.5)	12.2 (54.3)

For SI: 1 kip = 4.448 kN.

¹ Refer to Section 4.1.3 of ESR-2794 for descriptions of fixed condition, pinned condition, soft soil and firm soil.

² Strength ratings are based on a design corrosion level of 50-years and presume the supported structure is braced in accordance with IBC Section 1808.2.5, and the lead section with which the extension is used will provide sufficient helix capacity to develop the full shaft capacity.

DRAWINGS AND RATINGS

SS5 HELICAL PILE AND ANCHOR PRODUCT SPECIFICATIONS				
SHAFT	Hot Rolled Round-Cornered-Square (RCS) Solid Steel Bars per ASTM A29; modified AISI 1044 with 70 ksi minimum yield strength			
Shaft Size	1.50 in	38 mm	Corroded	
			1.487 in	37.8 mm
Moment of Inertia (I)	0.40 in ⁴	16.5 cm ⁴	Corroded	
			0.38 in ⁴	15.6 cm ⁴
Shaft Area (A)	2.2 in ²	14.2 cm ²	Corroded	
			2.16 in ²	13.94 cm ²
Section Modulus (S _{x-x})	0.53 in ³	8.7 cm ³	Corroded	
			0.40 in ³	6.6 cm ³
Perimeter	5.6 in	14.2 cm	Corroded	
			5.5 in	14 cm
Coupling	Integral Forged Square Deep Socket			
Coupling Bolts	One ¾ inch Diameter ASTM A325 Type 1 Hex Head Bolt with Threads Excluded from Shear Planes			
Helix Plates	0.375 inch Thick, Formed on Matching Metal Dies, ASTM A572 Grade 50 or better			
Coatings	Hot Dip Galvanized per ASTM A153 Class B-1, 3.1 mil minimum thickness or Bare Steel			
TORQUE PROPERTIES				
Torque Correlation Factor	10 ft ⁻¹		33 m ⁻¹	
Torque Rating	5,700 ft-lb		7,730 N-m	
STRUCTURAL CAPACITY				
Tension Strength	Nominal		LRFD Design	
	70 kip	312 kN	52.5 kip	234 kN
Allowable Tension Strength	35 kip		156 kN	
TORQUE CORRELATED CAPACITY				
Capacity Limit Based on Torque Correlation, Tension / Compression	Ultimate		Allowable	
	57 kip	254 kN	28.5 kip	127 kN

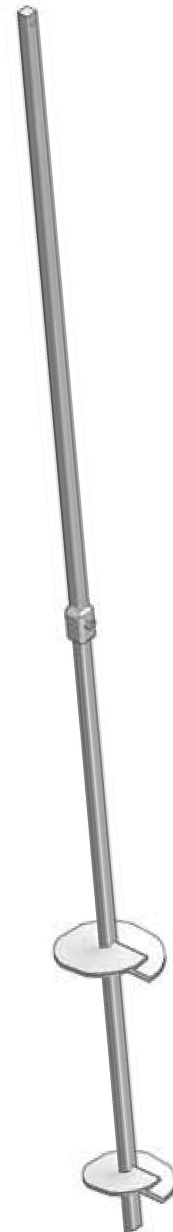

Assembly of SS5
Figure 7-6

ASD Allowable Compression Strengths of CHANCE® Type SS5 Helical Pile Lead & Extension Sections^{1,2}

Section Type & Helix Count	ASD Allowable Axial Compression Strength kip (kN)			
	Firm Soil		Soft Soil	
	Fixed	Pinned	Fixed	Pinned
Lead, Single Helix	<i>See Helix Strength Table</i>		16 (71.2)	8.1 (36.0)
Lead, 2-Helix 8"-10"	52.5 (233.5)	32.6 (145.0)	16 (71.2)	8.1 (36.0)
Lead, 2-Helix 10"-12"	45.9 (204.2)			
Lead, 2-Helix 12"-14"	49.9 (222.0)			
Lead, 2-Helix 14"-14"	53.8 (239.3)			
Lead, Multi-Helix	53.8 (239.3)	32.6 (145.0)	16 (71.2)	8.1 (36.0)
Extension	53.8 (239.3)	32.6 (145.0)	16 (71.2)	8.1 (36.0)

For SI: 1 kip = 4.448 kN.

¹ Refer to Section 4.1.3 of ESR-2794 for descriptions of fixed condition, pinned condition, soft soil and firm soil.

² Strength ratings are based on a design corrosion level of 50-years and presume the supported structure is braced in accordance with IBC Section 1808.2.5, and the lead section with which the extension is used will provide sufficient helix capacity to develop the full shaft capacity.